



FOLDING DOORS | PRODUCT SOLUTIONS



FOLDING DOORS have become the ultimate definition of the modern home, opening up over 90% of the interior living space to the adjacent exterior. These doors operate smoothly and effortlessly with a self-supporting frame and bottom roller system. Without lacking flexibility, our folding doors are designed to be the most solid, well engineered components in the market. An optional door locking principle allows the first leaf to be used as an entrance door for simple passage.



FEATURES / HIGHLIGHTS

- Bottom Roller System
- Self-Supporting Frame
- Opening configurations up to eight panels
- 4 ft. Wide Panels
- Inward / Outward Opening Configurations
- Single Man-Door for Simple Passage
- Classic (Steel Look) Design Variant

WINDOW & DOOR PRODUCT SOLUTIONS

HARMONIOUSLY WORKING TOGETHER FOR MAXIMUM VISUAL APPEAL

FOLDING DOORS | PRODUCT SOLUTIONS

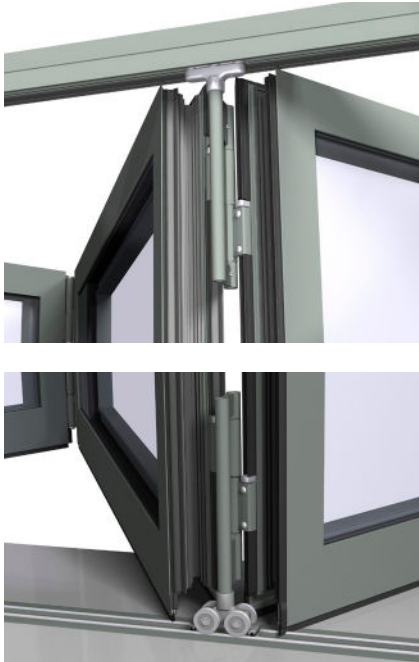

FOUR (4) FT. WIDE DOOR PANELS. Four (4) ft. wide panels improve sight lines and reduces the number of door sections, with a third less panels within a 12 ft. door opening compared to other solutions in the market.

BOTTOM ROLLER SYSTEM WITH SELF SUPPORTING FRAME. Our Folding door panels are supported by a bottom mounted track system for effortless door operation. With loads distributed among the bottom and top track, CF 77 door panels are the largest in the industry. The reduced loads allow the door frame to be self supporting and does not require any additional engineering for the structural support header of the door opening.



Flat Threshold		Low Threshold		Double Weather Seal Threshold		High Performance Threshold	
Below Grade	Above grade	Inside	Outside	Inside	Outside	Outside	Inside
1 (in.)	0 (in.)	13/16 (in.)	1 (in.)	1 5/8 (in.)	1 (in.)	3 1/8 (in.)	2 9/16 (in.)

FOUR (4) THRESHOLD OPTIONS. All folding door configurations are available with four (4) different thresholds; High Performance, Double Weather Seal, Low Threshold and Flat Bottom. With a step-up, the High Performance sill offers superior air, wind and water resistance. The Double Weather Seal balances good air, wind and water tightness with a decreased threshold and is well suited for renovation projects. A Low Threshold option offers a rise of only 11/16" with a partly recessed design. Finally the Flat Bottom design is intended for interior applications or areas with significant roof coverage, allowing for easy passage and maximum convenience in high traffic areas.

CONCEPT FOLDING **CF 77**

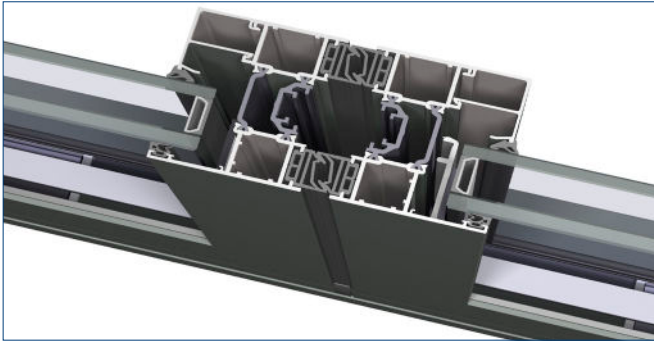

CF 77 Boasts a functional design that matches a large variety of design aesthetics while yielding the largest panes of glass in the industry with a wide range of solutions for inward and outward opening configurations.

CONCEPT FOLDING **CF 77-SL SLIMLINE**

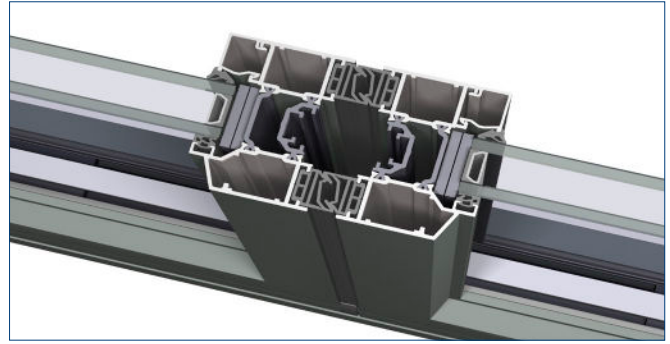

CF 77-SL SLIMLINE Featuring a narrower visible width with a classic design for a steel look, the Slimline variant offers the same inward and outward opening capabilities as the functional profile.



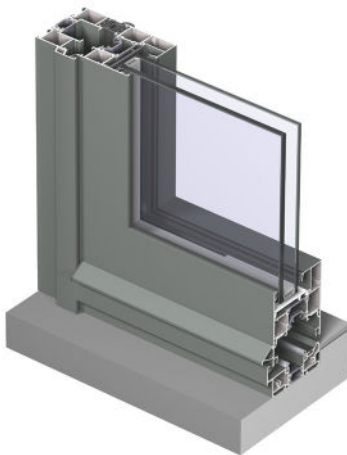

OPENING CONFIGURATIONS

2 PANEL	3 PANEL	4 PANEL	5 PANEL	6 PANEL	7 PANEL	8 PANEL
2-0-2	3-0-3	4-0-4	5-0-5	6-0-6	7-0-7	8-0-8
	3-1-2	4-1-3	5-1-4	6-1-5	7-1-6	8-1-7
		4-2-2	5-2-3	6-2-4	7-2-5	8-2-6
				6-3-3	7-3-4	8-3-5
						8-4-4



SINGLE MAN DOOR FOR EASY PASSAGE. With 22 different opening configuration options to choose from, the perfect door is just awaiting your approval. Choose the number of door leaves based on the opening size and decide if you want them to open inward or outward. Assess whether you want them to open all on one side or split with doors panels on each side of the opening. Lastly, an optional door locking principle allows the first leaf to be used as an entrance door without affecting the folding capacity of the system.

Profile Dimensions	System Depth (in.)	Visible Width (in.)		Max. Weight	Vent Max-Min Sizes (in.)				Min. Size (in.) 2 Panel Door		Max. Size (in.) 8 Panel Door	
	Frame-Vent	Frame-Vent	Meeting Section	Vent	Min.		Max.		Min.		Max.	
			Vent-Vent		lbs	W	H	W	H	W	H	W
CF 77 Functional Frame	3	4 11/16	5 11/16	264	16	29	47	116 7/6 120 w/Frame	36	29	380	120
CF 77-SL Slimline Frame		4 1/4	4 13/16									

				CF 77 Functional Frame		CF 77-SL Slimline Frame	
		Glazing	Double	Triple	Double	Triple	
	Thermal Insulation (Btu/hr-ft ² -°F)	Open In	Uw	0.36	0.28	0.36	0.28
			SHGC	0.18	0.14	0.18	0.14
		Open Out	Uw	0.36	0.28	0.36	0.28
			SHGC	0.18	0.14	0.18	0.14
	Acoustic Performance ASTM E90-09/1332	STC	N/A		N/A		
		OITC	N/A		N/A		
	Air Tightness (cfm/ft ²)		0.1		0.1		
	AAMA Rating		PG55 SP		PG55 SP		
	Water Tightness (psf)		8		8		
All results based on gateway sizes; vary depending on glass/profile combinations Above Uw & SHGC values do not necessarily work in combination							

REYNAERS ALUMINIUM is a symbol of high quality architectural windows and doors.

Reynaers continually leverages the latest world-wide technology to evolve our products into engineering marvels that are aesthetically breathtaking.

THERMALLY BROKEN. Reynaers exclusive state-of-the-art thermally broken technology uses fiberglass reinforced polyamide strips, providing a best-in-class insulating system for top-notch energy performance.

ROBUST CORNER CONNECTIONS. Reynaers superior fit & finish is most evident through the quality of our corner connection. Our corners are joined using corner cleats and keys. Profiles are then crimped with epoxy to tightly secure profiles in place.

ENGINEERED & TESTED. Reynaers products are engineered and tested to handle all types of environmental conditions, incorporating design pressures certified by AAMA (American Architectural Manufacturers Association) for structural performance with exceptional air and water tightness. Testing reports / product simulations are available for various product configurations.

DRY GLAZING. Dry glazing offers easier installation in any weather condition and allows for simple on-site glass replacement without requiring removal of frames or panels. This method provides the ultimate in air & water infiltration performance with gaskets on both sides of the glass.

HIGH PERFORMANCE GLASS. Reynaers products feature Guardian® glazing and Cardinal® glass. These panels include double or triple pane Low-E glass for maximum heat resistance and energy performance. Our systems have been certified by the NFRC with SHGC coefficients and U-values which go above & beyond most local code requirements.

DESIGNED IN EUROPE,
WELL CRAFTED IN AMERICA