



# OPTIONS



## The inside story on Norwood quality

1. **Double glazing.** Sealed insulating unit with 9/16" air space and reservoir glazing for complete contact.
2. **Fibreglass Screen.** Held firmly in place by a special 'T' spline.
3. **Venting.** Unique system ensures run-off of any moisture that may enter the glazing cavity.
4. **Step Up.** Extra deep step eliminates water infiltration – even in extreme conditions.
5. **Weather Check.** Located at subsill and outside casing. An extra barrier to weather infiltration.
6. **Double Weather Stripping.** Flexible bulb and polyflex weather stripping minimizes air infiltration.
7. **Guaranteed Factory Finish.** Durable, Norcoat factory finish or CASA stain for low maintenance and extra long life. Over 160 colours available.

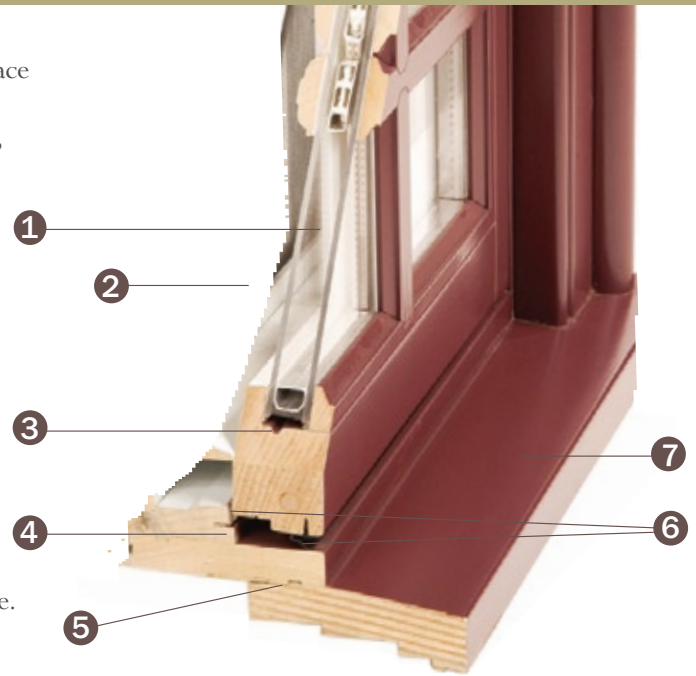

## Wood types and finishes



## Choose the type of wood.

Pine is fine and it's been our standard for decades, but today we create with many different species of wood. In fact, we are one of the few companies that will do this. If you don't see what you're looking for here, let us know and we'll see what we can do. Because 'can do' is something we say a lot at Norwood!

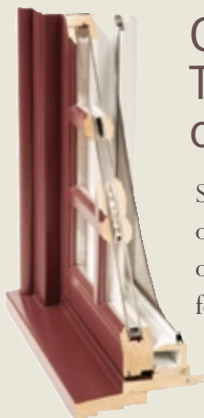

### Order a Two-Tone option.

Specify one colour or stain for the outside and another for the inside.

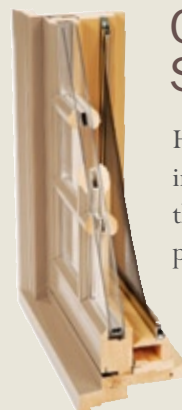

### Or choose Split-Finish.

Have the exterior done in one colour and leave the interior natural to paint or stain on site.



### You can even mix woods.

Here, a Mahogany window has a Cedar subsill.

**Get guaranteed Norcoat factory finish colours.** Choose our Norcoat factory finish and get beautifully coloured windows and doors without the maintenance hassles. With a 15-year guarantee, Norcoat is the industry's highest quality, exterior wood finish.

In the three-step process, components are soaked and coated twice before assembly for greater resistance to the elements than the finest paint. And, by offering over 160 standard colours, as well as endless custom colours, you get the flexibility you need to create a truly unique project. Many colours are displayed on our web site. Ask your dealer to see all the standard colours available.

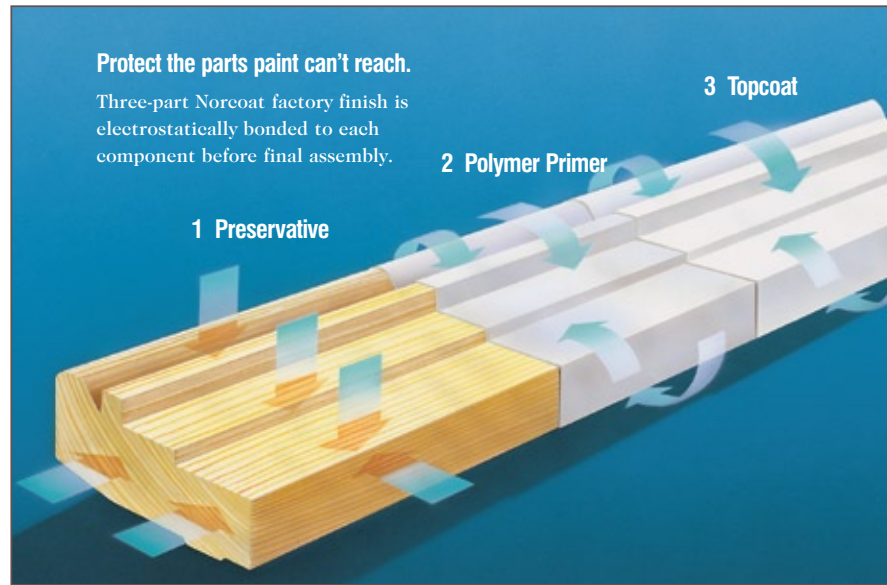

**Choose from over 160 standard and custom colours. (48 shown here)**

*Due to printing limitations, colours shown are approximations only. Consult dealer's Colour Board before ordering.*



**Or specify one of these factory stain options.**

Norwood is one of the few manufacturers to offer factory staining options. You can have the stain applied to either or both sides of the product. Our industry-leading CASA stains, from Laurentide, feature a six-step staining process that involves a specially-formulated sealant, the selected stain, and a protective satin clear coat – all applied to each component before assembly for unsurpassed protection against weather and UV.

Here, the stains are shown on Maple. Consult your dealer for actual samples.





Norwood screen options combine modern fit and function with old-world charm. Introducing Norwood screens – a comprehensive line of high-quality screens to match our single-hung, double-hung and casement series windows. Manufactured to the same exacting standards as our entire catalogue of fine window and door products, Norwood screens are sure to please those who appreciate both traditional craftsmanship and modern-day convenience.

## Traditional

Norwood screens are beautifully designed for both form and flexibility, allowing our customers to choose between screened and screen-free living with ease. Our traditional screens are available with both wooden and standard aluminum frames.



Full screen

Half screen

## Swinging Screens

Swinging screens are built standard with high-quality wooden frames matched to the colour of the window frame. Let your Norwood dealer help you decide which option is best for you



## Roll-down screens



Designed to fit our line of casement windows, roll-down screens are mounted at the top of the frame and simply roll down in front of the window when needed, and roll back up when not.

## Roll-up screens



Suitable for our single and double-hung lines, roll-up screens are magnetically attached to the bottom of the window, enabling them to follow the window up when opened. Don't want the screen? Simply lower it back to the sill.

Unless otherwise specified, all White products are equipped with White hardware and screen frames. All coloured products will come with Coppertone hardware and screen frames. Certain exceptions are the Bright Brass lockset handles on the Garden Patio Door and the variety of finish options on Pine French Door and Sliding Patio Door handles as shown lower on this page.

On windows with crank handles you can choose the T-Handle or Foldaway options for better clearance with close-fitting window blinds. Whatever your choice, you can depend on the integrity of Norwood's hardware for years of trouble-free operation and security.

### Casement Hardware



Our door hardware is available in a variety of finishes.

### Double Hung Hardware

Available in same finish as Casement Hardware

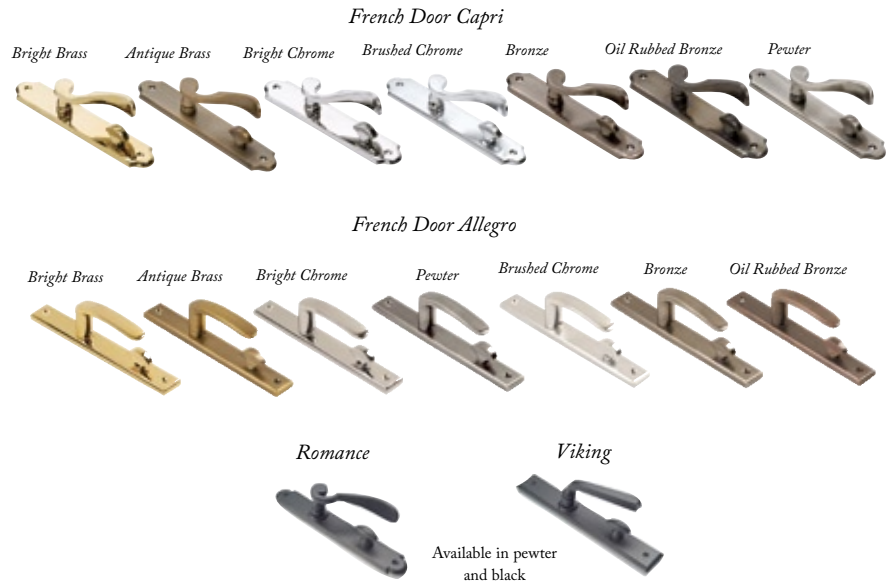

### Sash Locks from Phelps

Available in: Polished Lacquered Brass, Polished unlacquered Brass, Oil Rub Bronze, Satin Nickel, Polished Chrome

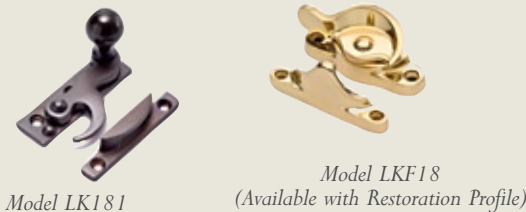

### Traditional Push Out Hardware for Casements

Available in: Antique Brass, Oil Rub Bronze and Bright Brass



### Wood entrance hardware finish colours.

From left: Antique Brass, Pewter, Bright Chrome, Bright Brass, Bronze, Brushed Chrome and Oil Rubbed Bronze.

# Grille Options

## Choose from a wide variety of grille options.

At Norwood, we offer the complete range of grille options, from our authentic style Vintage Series (SDL) divided lites to internal pewter, brass and white aluminum to removable wood. And we love to be challenged to build unusual patterns.

Enjoy the classic charm of Vintage Series (SDL) traditional divided lites. A variety of muntin bar profiles and sizes are available. You can order one profile on the exterior and another on the interior at no extra cost. You can even mix grille dimensions on one side. Aluminum spacer bars are available in the standard Brushed Aluminum or in Black or Grey.



## True Divided Light (TDL)

The rebirth of a classic! Norwood's new True Divided Light windows are built by modern-day craftsman trained in the specialized art of traditional window making. If you crave authenticity down to the smallest detail, the individual panes and ornate ribbing of our TDL windows will satisfy you like no other.

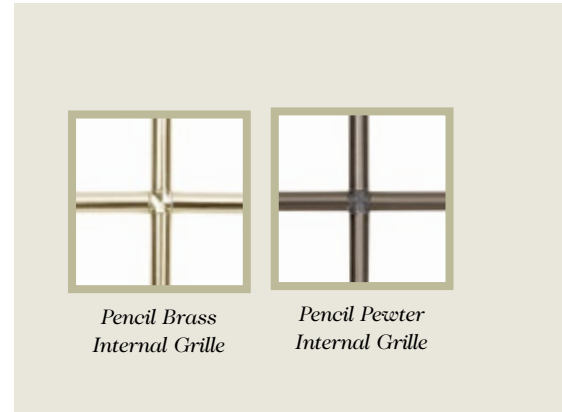
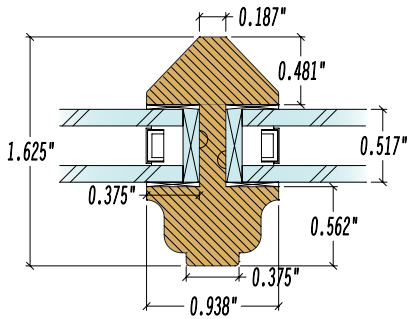

Baroque glass with Vintage grilles.



This custom Mahogany Vintage Series grille design in the Ovalo profile uses Cathedral glass.

### Restoration Height = $\frac{9}{16}$ "



### Heritage Height = 1"

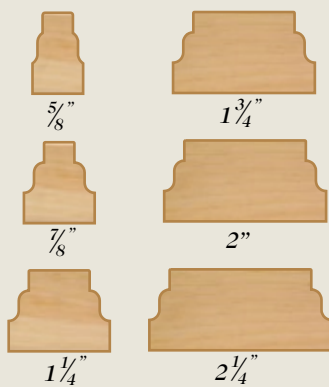

### Ovalo



### Putty

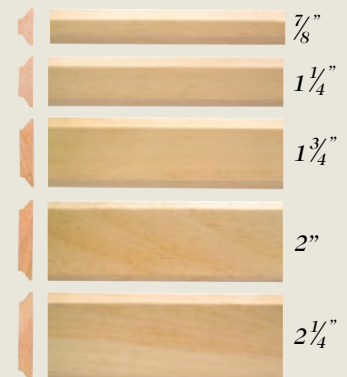

We also offer a wide variety of decorative glazing options.

Here are many of the most popular options. If you don't see what you're looking for we'll find it for you.

Ask about authentic beveled and film beveled glass.



Regular Aluminum Internal Grille



Georgian Aluminum Internal Grille



Amber Cathedral



Clear Cathedral



Baroque

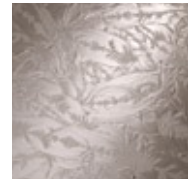

Glue Chip

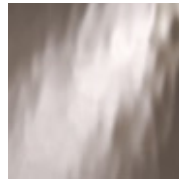

Water



Hammered



Obscure



Rain

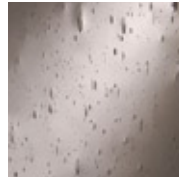

Seed

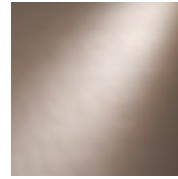

Solar Bronze



Solar Grey



Greylite

### Take divided lite detailing to another level with Leaded Lites.

Norwood brings traditional stained glass detailing into the 21st century with authentic style Leaded Lites. Today's version is a high-tech, energy-efficient 'glass sandwich' with continuous glazing and applied Leaded grilles both within the sealed unit and on the exterior. You can request Leaded Lites in any Norwood product. You can even create your own design for us to follow.

You can even create your own design for us to follow.



Solar Grey, Glue Chip and Baroque glass with Bright Brass and Patina Cames.



Silver Cames also available.



This design features, Clear Beveled, Cotswald and Glue Chip glass with Patina lead Caming.

At Norwood, preserving our planet is not only our responsibility, it's our priority. In the window and door industry, much of what we do relies heavily upon the consumption of natural resources. As such, Norwood places a strong emphasis on reducing our environmental impact through the development and implementation of green manufacturing and disposal processes.

- Scrap wood either unused or unsuitable for use in our premium windows and doors is put to good use in heating 40% of our manufacturing facility
- All products are built with sustainably-harvested lumber
- Any excess or broken glass is collected and returned to our supplier for immediate recycling
- Sawdust, an often troublesome byproduct of our business, is collected in silos, compressed and re-purposed to heat our dry lumber kilns
- All cardboard and paper waste associated with our operations is recycled on a weekly basis.



All of our premium doors and windows are manufactured to exacting standards of energy efficiency to ensure your home preserves heat in the winter and cold in the summer... like it's supposed to. Many of our products carry the internationally recognized ENERGY STAR<sup>®</sup> label. All ENERGY STAR qualified windows and doors meet the U.S. Department of Energy's and Natural Resources Canada's strict guidelines for energy preservation and conservation. Norwood windows and doors also carry an NFRC rating to assist homeowners and homebuilders in choosing products that will help their structure qualify for LEED certification. The Leadership in Energy and Environmental Design certification (LEED) is the nationally accepted benchmark for the design, construction and operation of high-performance, environmentally responsible buildings.

Norwood is proud to be a contributor in helping today's environmentally conscious contractors and homeowners have an immediate and measurable environmental impact through the construction of greener homes and buildings.



For more information please visit [www.energystar.gov](http://www.energystar.gov) for ENERGY STAR<sup>®</sup> standards in the U.S. or [www.energystar.gc.ca](http://www.energystar.gc.ca) for Canadian ENERGY STAR<sup>®</sup> information.



## Low-E Coating and Argon Gas save on energy and reduce interior fading.

Low-E (low emissive) coating is a thin, metallic film that is practically invisible to the naked eye. Argon Gas is a harmless, odourless, colourless gas from natural sources, with a higher insulation value than air.

Together, they make your home cooler in the summer, warmer in the winter and they reduce the harmful ultra-violet rays that can fade your interior surfaces. The insulating values of this popular Low-E Argon combo also reduce fuel consumption – good for the wallet and good for the environment.

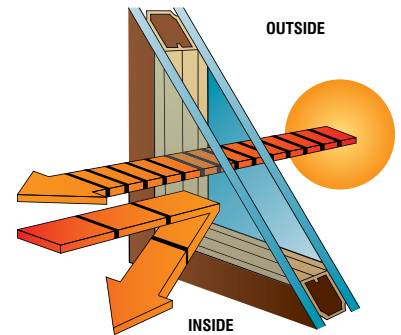

## Make double-glazed sealed units perform like triple-glazed.

Low-E coating forms a barrier to long-wavelength energy only. The sun's rays are short-wavelength radiation and easily pass through the window while the longer wavelengths of more harmful U-V rays are significantly reduced. Much of this solar energy is absorbed into the structure and furnishings, but the rest is re-radiated inside the house as long-wavelength energy.

Your heating and cooling systems also make long-wavelength energy. Uncoated glass absorbs most of this long-wavelength energy and re-radiates it to the outdoors. Low-E coating significantly reduces that thermal loss. The smaller amount of re-radiated energy that does make it out through the interior coated glass is then impeded by the Argon Gas inside the unit to help keep you warmer in the winter and cooler in the summer.

Please note that Low-E Coating is not available in some decorative glazing. Ask for details.





## Building a case for architectural harmony.

Norwood products typically have slender, elegantly proportioned casings suitable for many of today's architectural styles. In some cases, various architectural styles are better suited with the appropriate optional Casings, Backbands, Subsills and other trim features like Pediments, Pilasters and Keystones to name a few.

With Norwood, your products arrive completely assembled with all casing and trim elements in place saving you time and expense at the job site. Many of our Casing, Backband and Subsill profiles are shown on page 48 & 49. Your dealer can tell you more.



















## Custom Millwork

Norwood also specializes in custom millwork and can create the solutions you are looking for.



### Interior Casings

Depth X Width

 2349 1" X 3 1/2"	 816 13/16" X 3 1/4"	 2242 11/16" X 2 1/2"
 458 1 1/16" X 2 1/4"	 2125 3/4" X 3 1/4"	 2344 3/4" X 3 1/2"
 469 1 1/16" X 3 1/4"	 2138 3/4" X 3 1/2"	 634 3/8" X 4 1/8"
 635 5/16" X 3 1/8"	 2364 1 1/16" X 3 5/8"	 639 3/8" X 4 1/8"
 636 5/8" X 2 1/2"	 2349 1" X 3 1/2"	 2153 13/16" X 6"
 637 3/8" X 2 1/8"	 2254 7/16" X 1 3/4"	 468 1 1/16" X 6 3/16"

## Exterior Casings Depth X Width

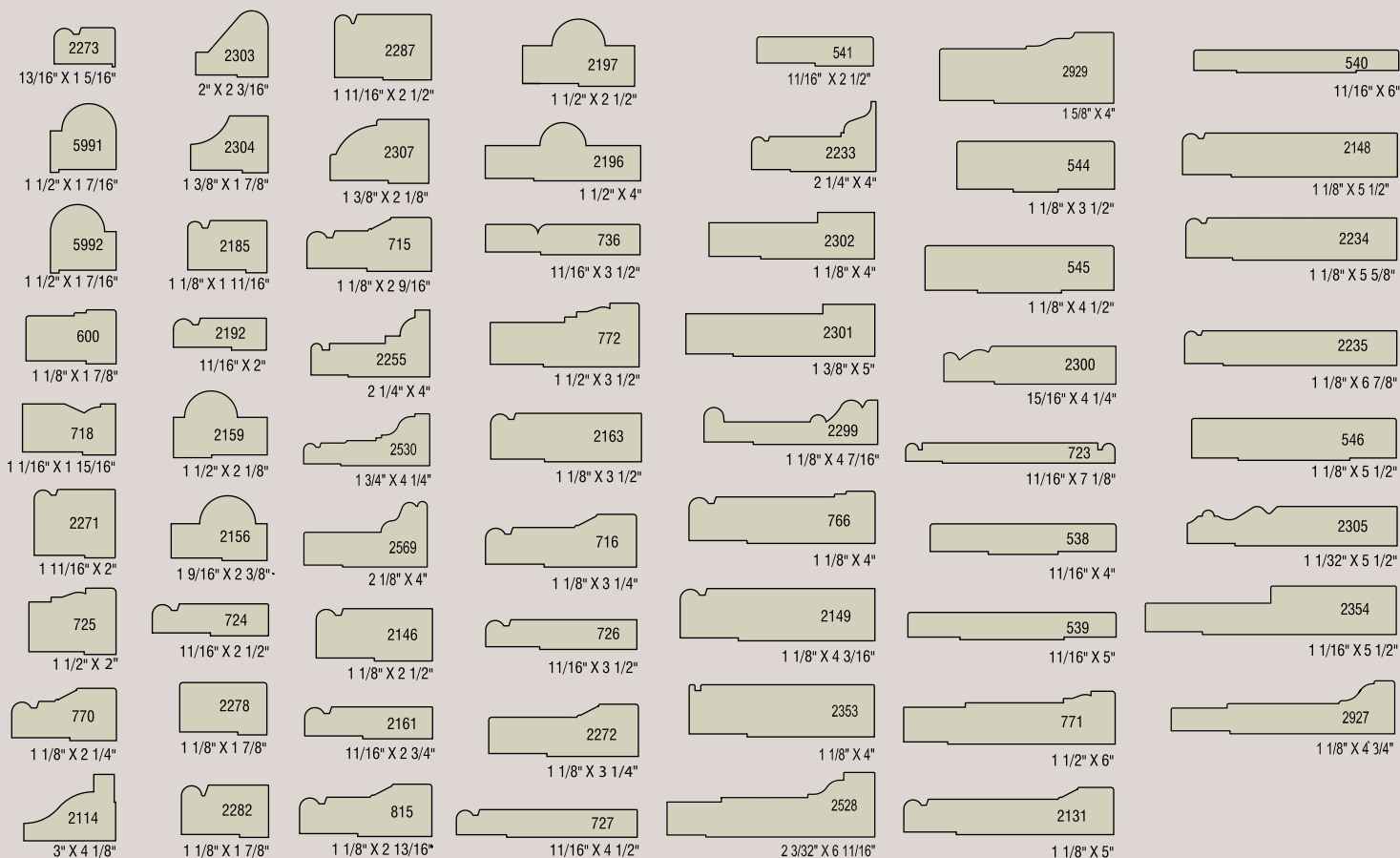

## Backbands Depth X Width

Backbands are designed to mix and match with various exterior casings.

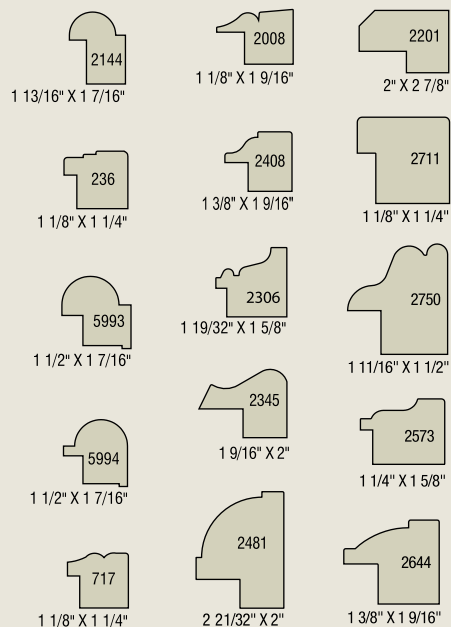

## Subsills Nose X Projection

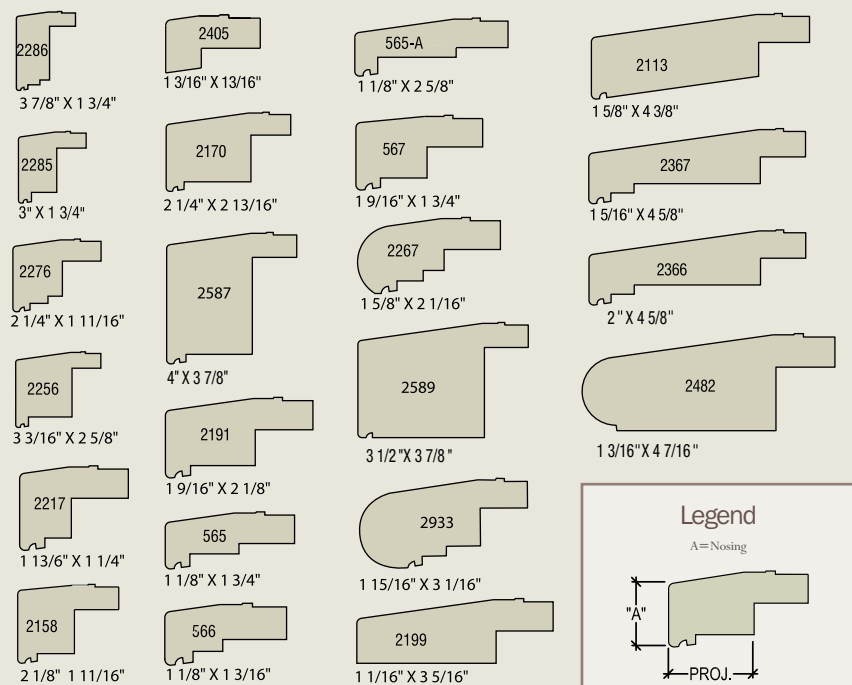

## Let us build the look you want.

Take a standard Single or Double Hung Window, add a Wide Board Casing and/or Pediment with Keystone.



P713

KP312

3 1/2"



1 1/4"

KP134

Top it off with handsome Pediments.



Keystones are available in three different sizes or we can make them as special orders.



P77

Pilasters are available for windows and doors.



We can also supply custom interior and exterior millwork.

Add Norcoat solid colour or CASA stain to match your doors and windows.

## Replace older windows easily with our sash replacement kits.

Preserve the authentic qualities of your older window casings by just replacing the sashes. Our sash replacement kits are available in all of our colours and stains or they can be left natural for you to finish. They are also available with the full variety of grille options. We can even match your specified sill degree angle.

The kit includes: the sashes; right and left compression jamb liners with block and tackle balances (white or beige); head parting stop; hardware; and a screw pack. Ask your dealer for assistance with ordering.



## Shutters

Norwood shutters are manufactured from top quality woods and available in a variety of colours to match your home.

